

DESCRIPTION

The INVALCO Series 510 Valve can be used for maintaining back pressure on vent lines from separators, treaters, dehydrators, compressor stations, gas gathering systems, etc.

FEATURES

- Ductile Iron Body** - Meets most application requirements.
- Soft Plug** - Allows for positive shut-off.
- Double-Port Design** - Allows for decreased flow.
- Nace Adaptable** - Can be modified for use in sour service.

SPECIFICATIONS

Body and Cover

Ductile A-395

End Connections

2", 3", 4" and 6" ANSI 150# RF Flanges

Diaphragm Case

Steel, 26 sq. in. or 65 sq. in.*

Diaphragm

Nylon reinforced Buna N

Temperature Limits

-20°F to 250°F**

Containment Pressure

100 psi **

Packing

Non-lubricated Buna-N

Stem

303 Stainless Steel****

Cages and Guides

304 Stainless Steel

Seats

2", 3", and 4"...304 Stainless Steel

6"...303 Stainless Steel****

Valve Plugs

2", 3", and 4" Replaceable Buna****

6" Viton O-Ring

Seat-to-Body Seals

O-Ring

Spring Ranges

0-100 psi (see chart on page 2)



Series 510 Back Pressure Valve

Pressure Increase Required From Full Closed to Full Open

Spring Range	Increase
0-25 psi	2.7 psi
20-40 psi	4.0 psi
40-60 psi	9.0 psi
60-100 psi	10.5 psi

General Notes

1. Refer to valve engineering section for valve sizing charts.
2. Cg-Cv is for fully opened valve.
3. Part numbers valid only if valve desired is exactly as described.

* **6" Only**
26 sq. in. Topworks for 40-60 and 60-100 Spring Range.
65 sq. in. Topworks for 0-25 and 20-40 Spring Range.

2", 3" and 4" Valves

26 sq. in. Topworks.

** Containment pressure is maximum working pressure and is limited by the diaphragm case. However, pressures above the maximum spring setting are uncontrolled and the back pressure valve will be fully open.

*** Limited by elastomers.

**** Consult factory for optional trim.

NATCO CANADA

www.natcogroup.com • 1-800-661-6628

SETTINGS

Any spring combination may be set to open at less than 5 psi working pressure, but, because the heavier springs are less sensitive, it is recommended that valves be selected to suit the pressure range required. Valve will be factory set to mid-point of range specified.

ORDERING INFORMATION

Size	Model Number	Flow		Spring Ranges and Part Numbers				
		Cv	Cg	0-25	20-40	40-60	60-100	Wt.
2"	RDFG-201-510	44	1,450	80006241	80006242	80006243	80006244	45
3"	RDFG-301-510	72	2,300	80006245	80006246	80006247	80006248	92
4"	RDFG-401-510	72	2,300	80006249	80006250	80006251	80006252	113
6"	RDFG-601-510	430	13,360	80006254	80006255	80006256	80006257	218

DIMENSIONS

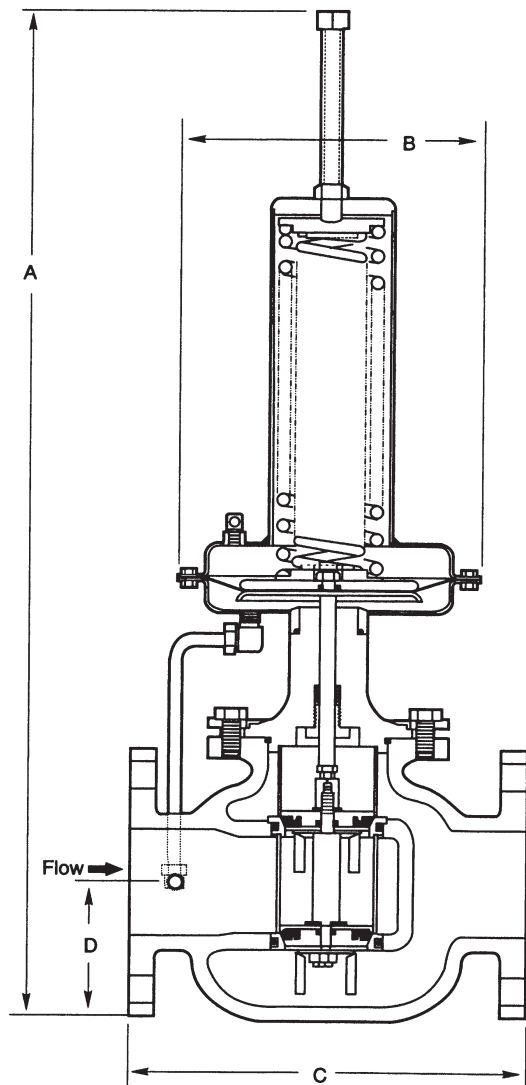

Model	A*	B	C	D
RDFG-201	24.4"	8.4"	8.0"	3.4"
	(618)	(213)	(213)	(29)
RDFG-301	25.5"	8.4"	11.0"	4.4"
	(646)	(213)	(279)	(111)
RDFG-401	25.5"	8.4"	12.8"	4.6"
	(646)	(213)	(324)	(117)
RDFG-601-510 (26 sq. in. Top Works)	35.8"	8.4"	14.5"	7.7"
	(910)	(213)	(367)	(196)
RDFG-601-510 (65 sq. in. Top Works)	36.3"	12.5"	14.5"	7.7"
	(922)	(318)	(367)	(196)

Note: Dimensions – Inches to the nearest tenth (millimeters to the nearest whole mm), each independently dimensioned from respective engineering drawings.

*Clearance to remove adjusting screw.

Cv-Cg values for full open valve.

Part numbers valid only if valve is exactly as described.

PARTS 2", 3" AND 4" VALVES

Item	Description	Qty.	Part Number	
			2"	3" & 4"
1	Screw 5/8-11x5-1/2 SQHSS	1	65015572	65015572
2	Nut 5/8-11 Hex	1	65002136	65002136
3	Upper Diaphragm Case	1	48004283	48004283
4*	O-Ring BUN-012-90	1	67102312	67102312
5	Lower Spring Rest	1	45003992	45003992
6	Nut 3/8-24 Flexloc	1	65001401	65001401
7	Upper Diaphragm Plate	1	45005496	45005496
8	Screw 5/16-18x3/4 HHCS	12	65002073	65002073
9*	Diaphragm	1	45003465	45003465
10	Nut 5/16-18 Hex	12	65002100	65002100
11*	O-Ring BUN-225-90	1	67101099	67101299
13	Packing Nut	1	45001939	45001939
15	Screw 3/8-16x7/8 HHCS	4	65003440	----
	Screw 1/2-13x1 HHCS	4	----	65002852
16	Nut 2" (3/8-24 Hex Jam)	1	65002513	65005386
	3" and 4" (1/2-20 Hex Jam)			
17@	Stem Connector	1	45010518	45010521
18*@	O-Ring BUN-110-90/BUN-112-90	2	67101532	67101408
19*@	Upper Seal	1	45002423	45003359
20*@	Lower Seal	1	45002424	45003359
21*@	O-Ring BUN-228-90	1	67101530	----
*@	O-Ring BUN-234-90	1	----	67101736
22@	Upper Seal Retainer	1	45002432	45003392
23@	Lower Stem Guide	1	45002435	45003386
24@	Nut 3/8-24	1	65003075	----
@	Nut 1/2-20 Flexloc	1	----	65003402
25@	Lower Valve Plug	1	45002436	45003395
26*@	O-Ring BUN-228-90	1	67101530	----
*@	O-Ring BUN-233-90	1	----	67102331
27@	Seat Cage	1	45016100	45016102
28@	Lower Stem	1	45002429	45003385
29@	Upper Stem Guide	1	45002434	45003384
30@	Cage Spacer	1	45002431	45003389
31@	Upper Valve plug	1	45002436	45003390
32	Upper Stem	1	45010519	45010520
33*	O-Ring BUN-230-90	1	67101540	----
*	O-Ring BUN-237-90	1	----	67102334
34	Clamp Ring	1	45003128	45003413
35	Tubing 3/8 304 SS	16"	11032059	11032059
36	Elbow 1/4 NPT x 3/8 Tubing	2	45016252	45016252
38*	Packing Ring 1/2" x 1" Flat	1	45001948	45001948
39	Packing Ring 1/2" x 1" Reg.	3	45001947	45001947
40	Lower Diaphragm Plate	1	45003466	45003466
41	1/4" Bleeder Filter	1	45002612	45002612
42	Coupling 1/4" NPT	1	50100001	50100001
43	Nipple 1/4" NPT	1	45006875	45006875
44	Body RDFG-201-510	1	45012099	----
	Body RDFG-301-510	1	----	45012100
	Body RDFG-401-510	1	----	45012101

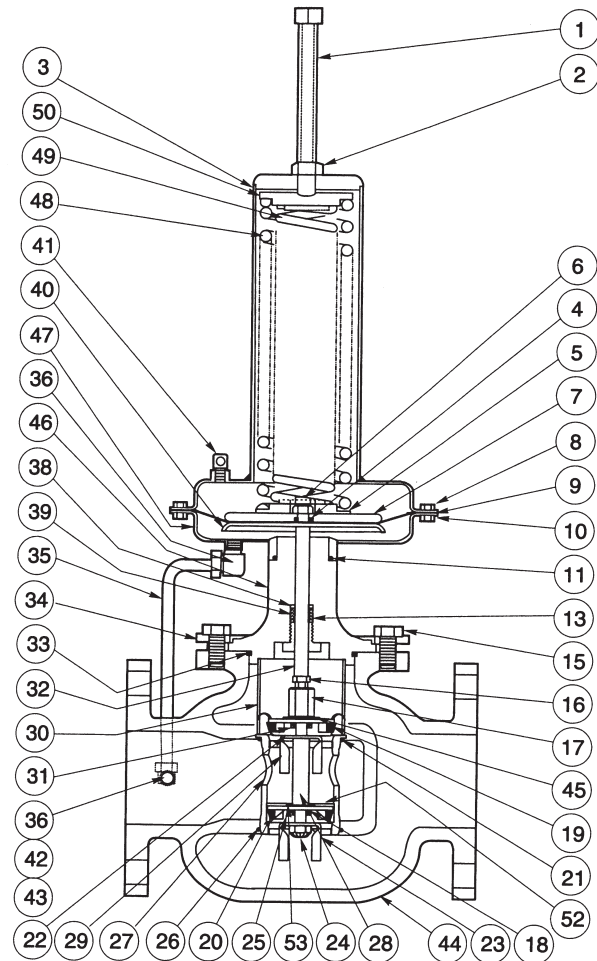

Item	Description	Qty.	Part Number	
			2"	3" & 4"
45@	Washer 3/8" Lock	1	65004401	----
@	Washer 1/2" Toothlock	1	----	65005389
46	Body Cover	1	45015533	45015639
47	Lower Diaphragm Case	1	48004018	48004018
48*	Outer Spring		See Chart	See Chart
49*	Inner Spring		See Chart	See Chart
50	Upper Spring Rest		45003991	45003991
52@	Lower Seal Retainer	1	45002433	45003392
53*@	Shim .005 (Not Shown)	6	45012494	45012496

@These items included in Valve Trim Kit. (2" Kit P/N 83000112, 3" and 4" Kit P/N 83000113)

*Recommended Spare Parts.

Setting Range (psi)	Item 48 Outer Spring	Item 49 Inner Spring
0-25	45003086	----
20-40	45003086	45003421
40-60	45003941	----
60-100	45003941	45003940

NATCO CANADA

www.natcogroup.com • 1-800-661-6628

FMC INVALCO

PARTS 6" VALVES

Item	Description	Qty.	Part No.
			6" Valve
1	Screw 5/8-11x5-1/2 SQHSS	1	65015572
2	Nut 5/8-11 Hex	1	65002136
3*	O-Ring BUN-012-90	1	67102312
4	Stem	1	45006446
5	Body Cover	1	45012567
6*	O-Ring BUN-437-90	1	67106179
7	Nut 1/2-20 Hex Jam	1	65005386
8*@	O-Ring BUN-254-90	1	67106178
9@	Upper Seat	1	45006269
10@	Seat Spacer	4	45006274
11@	Stem	1	45006272
12*@	O-Ring VIT-346-75	2	67306345
13*@	O-Ring BUN-253-90	1	67106265
14@.	Plug Washer	2	45006271
15@	O-Ring BUN-110-90	2	67101532
16@	Nut 3/8-24 Flexloc	1	65003075
17@	Lower Seat	1	45006268
18@	Valve Plug Body	2	45006270
19@	Screw 1/4-20x7/8 SHCS	12	65006180
20@	1/4" Lockwasher	8	65006386
21@	3/8" Lockwasher	1	65004401
22@	Stem Adapter	1	45006273
23	Hinge Pin	1	45006265
24	Cotter Pin	1	79006147
25@	Hold Down Pin	4	45006275
26	Stem Connector	1	45006447
27	Body, 6" Flanged Globe	1	45014487
28	Screw 1/2-13x1-1/4 HHCS	8	65000176
29	Packing Nut, (Pre-1988)	1	45015532
	Packing Nut, (Post-1988)	2	45001939
30	O-Ring BUN-112-90 (Pre-1988)	1	67101408
31*	Gasket, (Pre-1988)	1	45007261
32	Elbow 1/4 NPTx3/8 Tubing	2	45016252
33*	O-Ring BUN-225-90	1	67101299
34	Nut 3/8-24 Flexloc	1	65001401
35	1/4" Bleeder Filter	1	45002612
36	Lower Spring Rest	1	45003992
37*	Inner Spring	1	45003940
	(20-40 and 60-100 Ranges Only)		
38*	Outer Spring	1	45003941
39	Upper Spring Rest	1	45003991
40	1/4" NPT Coupling	1	50100001
41	1/4" NPT Nipple, 2-3/4" Long	1	45006289
42	2" Steel Pipe Plug	1	45011095
43#	Sight Glass, (Pre-1988)	1	45004223
44#	Nut 3/8-16 Hex	1	65001966
45#	Bushing, (Pre-1988)	1	45003129
46#	Spring (Pre-1988)	1	45004315
47#	Indicator Pin, (Pre-1988)	1	45005273

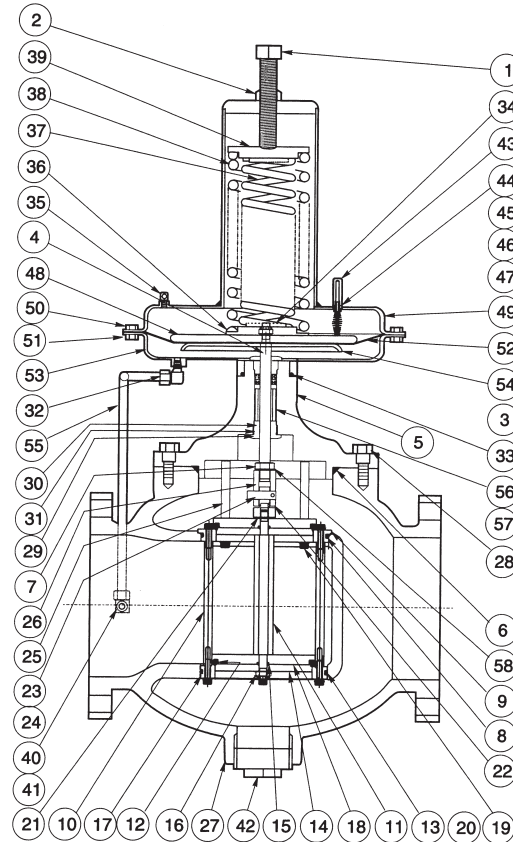

Item	Description	Qty.	26 sq. in.	65 sq. in.
			Top 40-60 & 60-100 lb. Range Part No.	Top 0-25 & 20-40 lb. Range Part No.
48	Upper Diaphragm Plate	1	45005496	1 45002776
49	Upper Diaphragm Case	1	48004283	1 48006248
50	Screw 5/16-18x3/4 HHCS	12	65002073	-- ----
	Screw 3/8-16x7/8 HHCS	--	----	16 65003440
51	Nut 5/16-18 Hex	12	65002100	-- ----
	Nut 3/8-16 Hex	--	----	16 65001966
52*	Diaphragm	1	45003465	1 45003460
53	Lower Diaphragm Case	1	48004018	1 48003459
54	Lower Diaphragm Plate	1	45003466	1 45001789

Item	Description	Qty.	6" Valve
			Part No.
55	Tubing 3/8 304 SS	18 in.	11032059
56*	Packing Ring 1/2x1 Regular (Post-1988)	2	45001947
57*	Packing Ring 1/2x1 Flat (Post 1988)	2	45001948
58@	Washer 1/2 Tooth Lock	1	65005389

Note: Dimensions -- Inches to the nearest tenth (millimeters to the nearest whole mm), each independently dimensioned from respective engineering drawings.

*Clearance to remove adjusting screw.

Cv-Cg values for full open valve.

Part numbers valid only if valve is exactly as described.