

CHAPTER 19

Level Control/
Capacitance and
Conductance

Company Name _____

Attention _____ Phone _____

Address: Street _____

City _____ State _____ Zip _____

Type of Control Desired

High level alarm Low level alarm Continuous level mounting Throttling

Output Desired

Alarm Analog Electrical Pneumatic Interface

Number of Systems Required _____

Type of Controller Desired

Float RF Conductance Capacitance

Characteristics of Material to be Monitored

Product Name _____

Liquid _____ Granular _____ Size of Granules _____ Powder _____

Slurry _____ Foam _____ Specific Gravity _____ Viscosity _____

Dielectric Constant _____ Resistivity _____

Check the following materials that are compatible with your process.

Steel Teflon Tungsten Carbide Stainless Steel
 316 Stainless Steel Monel Hastelloy B or C

Process Description

Material Buildup

Conditions above product

Temperature _____ Nil _____ Steam _____

Shell _____ Moderate _____ Dusty _____

Inside _____ Extreme _____ Condensate _____

Pressure _____ Other _____

Vibration/Agitation _____ Approx. Rate of fill or drain _____

Length of Control Range Required _____

Housings Required: Explosion-proof Weather-proof Panel Mounting

Power Available: 12 Vdc 24 Vdc 115 Vac 220 Vac

Air _____ psi _____ Accuracy required _____

To be completed for RF or Conductance type controls

Probe Mounting: Vertical Horizontal

Distance from process connection to control point _____ is automatic cycling required? _____

Length of coaxial cable for remote mounted units _____

Process Connection _____

Vessel Material _____ Lining inside vessel _____

DESCRIPTION

The superior design of the **INVALCO Interface Measurement System** offers reliable, precise control of gas/liquid or liquid/liquid interface level. Carefully matched electronic assemblies with probe components combine to provide a measurement system for the most demanding applications. A wide variety of standard features and ease of installation give the IMS 780 the flexibility necessary for optimum performance. The Interface Measurement System (IMS) has been carefully designed for dedicated interface control and surpasses all other multipurpose devices.

FEATURES

Excellent Sensitivity and Repeatability - means precision control even with difficult applications.

Non-Fouling Probe - for continuous, reliable use.

Convenient Operator Interface - provides visual status indication and greatly reduced set-up time.

Individually Adjustable Dual Outputs with Time Delay - allows the flexibility needed to change and customize control of your system.

Approved for use in hazardous locations. cUL and UL approved. Class 1 Groups C & D. 110/220 VAC or 24 VDC 6 watts.

Probe length variations available. Consult factory. Standard probe designs and lengths shown on page 3.

THEORY OF OPERATION

The INVALCO IMS Model 780 works on the principle of measuring an electrical value, called capacitance, that exists from its probe to ground. It does this by measuring the dielectric constant (dk) value of the material surrounding the probe and the distance from the probe to the nearest, and largest, ground plane which normally is the conductive water below the oil/water interface. The capacitance value will increase if the material dk increases, or if the water moves closer to the probe. Conversely, the capacitance will decrease if the material dk decreases, or if the water moves away from the probe. The main, dominating, factor is the distance from the probe to the water which thereby allows the IMS 780 to be a superior level indicator/control device. The unit is sensitive to extremely small changes (± 0.3 pf) and with a horizontally mounted probe, can be set to measure a clean interface as much as 24 inches away, depending upon fluid characteristics.

The use of capacitance to detect interface levels



Model 780 Interface Measurement System

in many applications has always been complicated by the electrical conductivity of the fluids and the buildup of conductive materials on the probes. These cause changes in conductivity which are mistaken for changes in capacitance, resulting in a misinterpretation of the interface level, or instrument failure. Interference caused by changes in conductivity are virtually eliminated by the use of high frequencies in the INVALCO IMS detection circuit design. Normally, high frequency requires the use of special cable (coaxial) to carry the signal which introduces other complications. The high frequency oscillator and detection circuitry in the INVALCO IMS are mounted in the probe and overcome the need for special cable. The control unit can be remotely mounted up to 500 feet away.

APPLICATIONS

Petroleum and Gas

- Separators
- Heater Treaters
- Desalters
- Free-water Knock-out

Other Industrial Liquid Processing

- Storage Tanks
- Extraction Units
- Separation Equipment

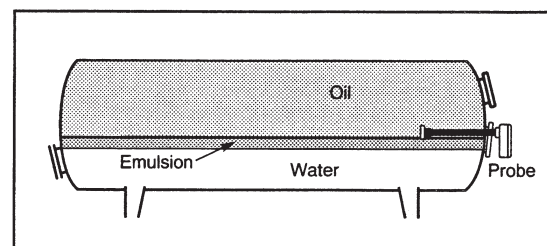

Figure 1 Various Probe Locations

NATCO CANADA

www.natcogroup.com • 1-800-661-6628

IMS MODEL 780

The Model 780 is designed to provide both a continuous (throttling) and snap-acting (on/off) output mode.

The snap-acting selector is a 10-position switch. The zero position is normally used when the Model 780 is used to detect a gas/liquid interface. Positions 1-9 are used to detect ever-increasing concentrations of water-in-oil.

Position 1 is nearest 100% oil, position 9 is nearest 100% water.

The Model 780 is also capable of developing a 4-20 mA throttling output which is particularly effective when applied to free-water knock-outs, treaters (crude oil dehydrators), wash tanks (gun barrels), skim tanks, three-phase separators, and other process vessels where an interface level must be maintained at a reasonable constant level.

The throttling selector has four positions marked 1, 2, 3, and 4. These positions correspond with the instruments overall span with respect to the water content of the oil at the interface.

Though actual water concentrations corresponding to the four positions vary with the different characteristics of oil and water, the general ranges follow:

Position 1	0-25% Water
Position 2	0-50% Water
Position 3	0-75% Water
Position 4	0-100% Water

INSTALLATION AND START-UP

The Model 780 probe may be installed horizontally, vertically, or at an angle. A horizontally mounted probe will be able to detect an interface further away than a vertical or angle mounted probe due to the area of the probe which is parallel to the interface. A horizontally mounted probe will have the entire length and width of the probe's electrode parallel to and "looking down" to the interface while a vertical, or angle mounted probe will have only the circular area of the end of the probe electrode "looking down" to the lower interface.

Normally a horizontally mounted probe is used when it is desired to control an interface below the probe while a vertical, or angle mounted probe is used when it is desired to control the interface on the probe electrode proper.

A packing gland on the probe allows it to be installed into, or removed from, a vessel without having to depressurize, or drain down, the vessel.

A single screwdriver calibration potentiometer is adjusted to set up the instrument for level control or interface control. Then simply turn the two knobs on the face of the 780 to get the desired relay and 4-20mA outputs. Then turn the time delay knob to eliminate any relay chatter caused by ripples, or waves, on the interface surface.

SPECIFICATIONS

Operating Temperature	-20°F to 160°F
Probe Temperature	250°F Maximum
Power	110/220 VAC, 50/60 Hz or 24 VDC 6 watts
Maximum Working Pressure	350 psig @ 100°F
Outputs	Continuous - 4 to 20 mA
Relay Contacts-DPDT, 10 Amps at 115 VAC non-inductive	
Fail-safe Mode	Low Level
Sensitivity	+/- 0.3 pf
Response Time to a dk Change	0.75 seconds or less.
Enclosures	Weatherproof - NEMA 4X Explosion-proof - Class 1, Groups C and D.
Adjustable Time Delay For Relay Closure	0-55 Seconds

Certification for Use in Hazardous Areas

Probe is certified for use with either W.P. or X.P. housed control unit. X.P. housed control unit is certified for use in hazardous areas.

cUL and UL approved

File: E215164

Type: Class 1, Groups C & D

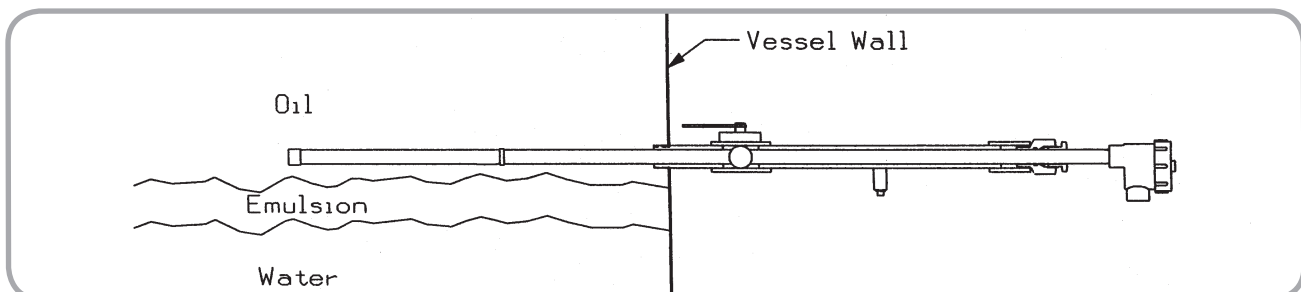

Probe Mounting on Vessel Wall Through a 1" NPT Ball Valve

DIMENSIONS/FEATURES

Model 780 Interface Measurement System

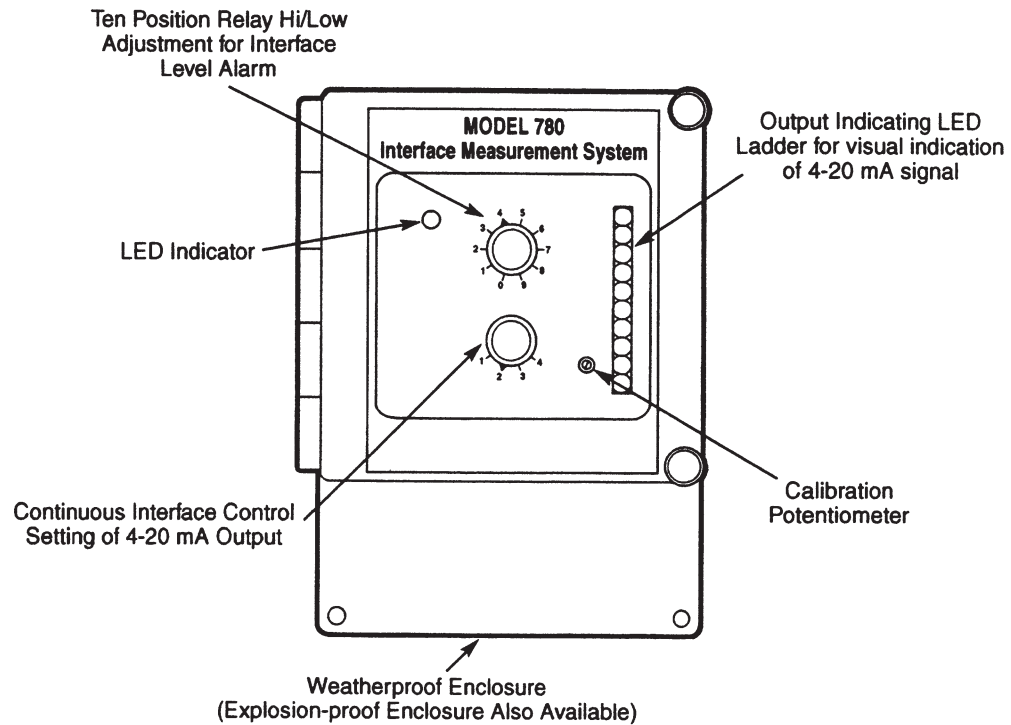

IMS 780 Probe without Extension Pipe p/n 81001059

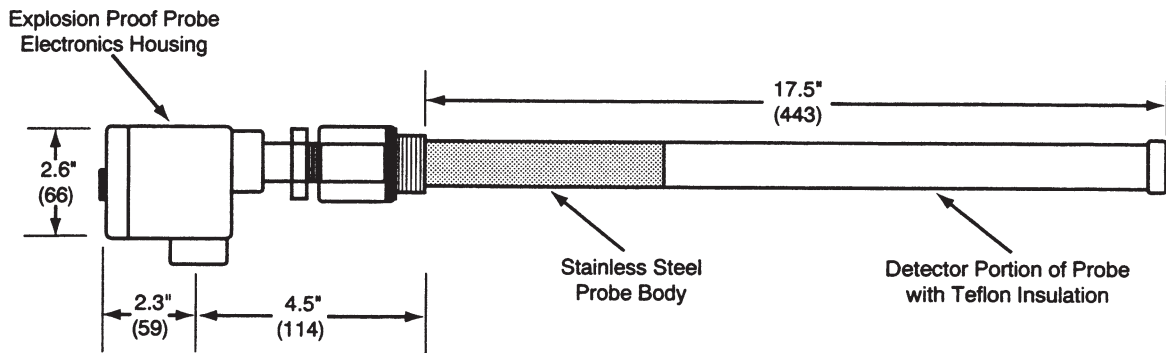

IMS 780 Probe with Extension Pipe, Full open ball valve and drain port p/n P514019

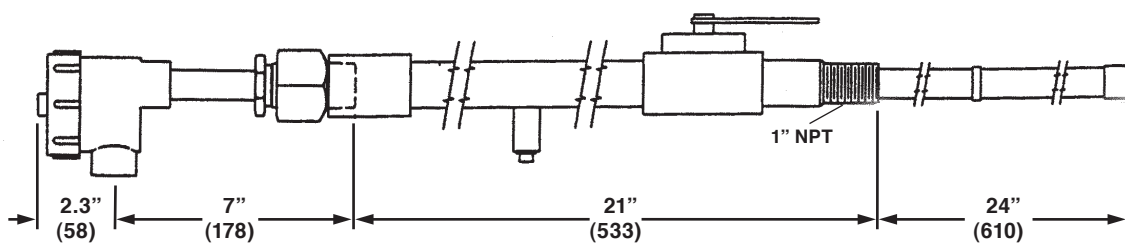

Note: Dimensions – Inches to the nearest tenth (millimeters to the nearest whole mm), each independently dimensioned from respective engineering drawings.

DIMENSIONS

Inches (mm)

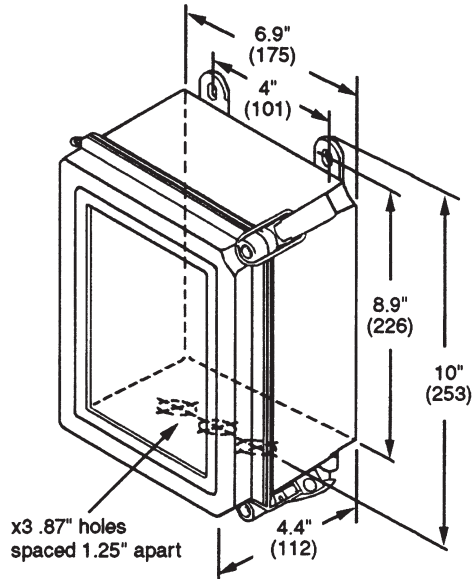

NEMA 4X Weatherproof Housing

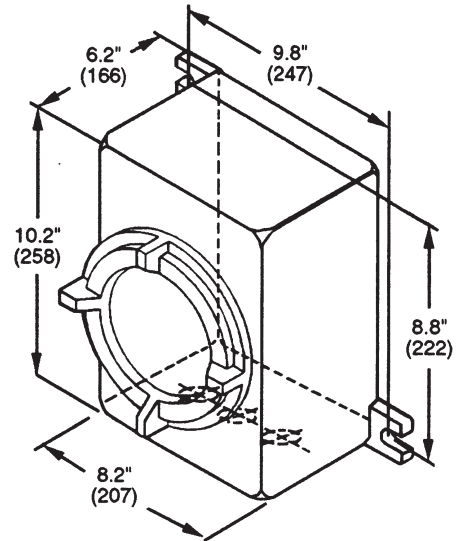

NEMA 7 Explosion-Proof Housing

Note: Dimensions – Inches to the nearest tenth (millimeters to the nearest whole mm), each independently dimensioned from respective engineering drawings.

System with Probe without Extension Pipe Assembly

Model No.	110VAC 50/60 Hz	Part Number
Model 780-XP	Interface Measurement System - Explosion-proof - NEMA 7, w/Probe and 20 ft. of Cable	81001055
Model 780-WP	Interface Measurement System - Weatherproof - NEMA 4X, w/Probe and 20 ft. of Cable	81001057
	Probe Assembly c/w PC701 Detector Card	81001059
Model No.	220VAC 50/60 Hz	Part Number
Model 780-XP	Interface Measurement System - Explosion-proof - NEMA 7, w/Probe and 20 ft. of Cable	81001052
Model 780-WP	Interface Measurement System - Weatherproof - NEMA 4X, w/Probe and 20 ft. of Cable	81001053
	Probe Assembly c/w PC701 Detector Card	81001059
Model No.	24 VDC	Part Number
Model 780-XP	Interface Measurement System - Explosion-proof - NEMA 7, w/Probe and 20 ft. of Cable	81001054
Model 780-WP	Interface Measurement System - Weatherproof - NEMA 4X, w/Probe and 20 ft. of Cable	81001152
	Probe Assembly c/w PC701 Detector Card	81001059
Chassis	110 VAC 50/60 Hz includes Relay LED Ladder	81001050
Chassis	220 VAC 50/60 Hz includes Relay LED Ladder	81001049
Chassis	24 VDC includes Relay LED Ladder	81001151
Probe	Std. Probe Only, No Detector Card, No Extension Pipe	81001060
Detector	PC701 Detector Card Fits All Probes	49020038

System with Probe with Extension Pipe Assembly

Model No.	110 VAC 50/60 Hz	Part Number
Model 780-XP-E	Interface Measurement System - X.P. NEMA 7 w/Probe with Ext. Pipe, Valve, 20' Cable	P514037
Model 780-WP-E	Interface Measurement System - Weatherproof - NEMA 4X, w/Probe and 20 ft. of Cable	P514987
	Probe Assembly c/w extension pipe, valve, drain, and PC701 Detector Card	P514019

Notes on probe P/N P514019:

- (a) The extension pipe is one inch, complete with a full opening one inch ball valve (for isolation purposes) and a 1/4" drain with plug.
- (b) The probe used with the extension pipe has two welded on safety rings, one on each end, to preclude the expulsion of the probe by pressure.
- The probe is removed from the vessel by loosening the packing nut behind the mounting hub and pulling the probe out until the front safety ring hits the forward end of the mounting hub. The ball valve is then closed and the drain opened. After pressure is released, and fluid drained out, the mounting hub is unscrewed from the collar on the extension pipe allowing the probe to be removed.

DESCRIPTION

The INVALCO Model 9450 Leveltronic Control Unit is a conductance level switch for detecting the level of a conductive material. When a conductive material comes in contact with the electrode, the electrode is “shorted” and current is able to establish an electrical path to ground. The unit responds to the “short” by actuating a relay.

By using an interlock (wiring the probe connections to an unused relay contact), it is possible to cause the unit to control a level between high and low level probes. The Leveltronic is switchable between High Level Fail-safe (HLFS) and Low Level Fail-safe (LLFS) and comes equipped with an adjustable sensitivity for substances with different conductivity measurements.

FEATURES

Adjustable - Sensitivity from 0 to greater than 250K Ohms of probe covered resistance for precise foam control.

Selectable - High or Low Fail-safe.

Safe for Operators - less than 6 volts potential on probes and less than 20 microamps nominal current flow.

Variety of Power Inputs - 18-32 Vdc, 115 Vac or 230 Vac 50/60 Hz.

L.E.D. - to indicate relay energized status.



Model 9450 Control Unit

SPECIFICATIONS

Sensitivity	0 - 250K Ohms
Power	18-32 Volts DC 104-127 Volts AC, 50/60 Hz 207-253 Volts AC, 50/60 Hz
Relay Contacts	DPDT, Form C Contact (Break before make) Max. Current: 7.5 Amps, Noninductive Max. Voltage: 115 Volts AC
Maximum Distance from Probe to Control	300 Yards (900 feet)
Operating Temperature	-40°F to 185°F (-40°C to 85°C)
Housing	NEMA 1, Optional NEMA 4X and NEMA 7
Socket	11 Pin Octal Socket for Mounting 9450 Control Unit

DIMENSIONS

Model 9450 Enclosure

Inches (mm)

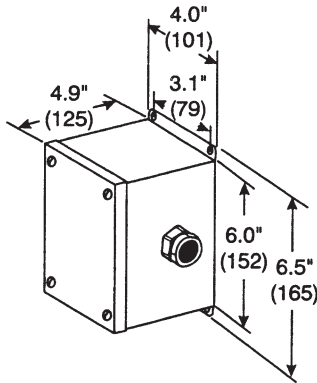

Nema 4 Weatherproof Housing

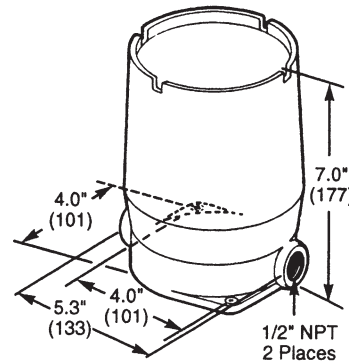

Nema 7 Explosion-Proof Housing

Note: Dimensions – Inches to the nearest tenth (millimeters to the nearest whole mm), each independently dimensioned from respective engineering drawings. Refer to Page 6 for Ordering Information on the Nema 4 Weatherproof and the Nema 7 Explosion-Proof Housing.

ORDERING INFORMATION

Model 9450 Control Unit (order separately)

Part No.	Description
81001847	Model 9450 Control Unit, High or Low Level Fail Safe - 24 VDC - Mates w/7450 Enclosure
81001848	Model 9450 Control Unit, High or Low Level Fail Safe - 115 VAC - Mates w/7450 Enclosure
81001849	Model 9450 Control Unit, High or Low Level Fail Safe - 220 VAC - Mates w/7450 Enclosure

Model 9450 Control Unit & Housing (order separately)

Part No.	Description
81001847	Model 9450 Control Unit, High or Low Level Fail Safe - 24 VDC - Mates w/11 Pin Socket
81001848	Model 9450 Control Unit, High or Low Level Fail Safe - 115 VAC - Mates w/11 Pin Socket
81001849	Model 9450 Control Unit, High or Low Level Fail Safe - 220 VAC - Mates w/11 Pin Socket
68215443	Octal Socket for Model 9450 Control Unit, Remote Mount
68221612	Octal Socket for Model 9450 Control Unit, (Included with Weatherproof and EXP Housings)
81001784	Weatherproof Housing for Model 9450 Control Unit, Includes 11 Pin Octal Socket
81001785	Explosion-Proof Housing for Model 9450 Control Unit, Includes 11 Pin Octal Socket